

**MINISTERE DES TRANSPORTS**

Luxembourg, le 06 mai 2003  
19-21, Boulevard Royal  
L-2910 Luxembourg  
Tél 478-1 – Télécopieur 241 817 – Télex 1465 CIVAIR LU

REFERENCE: CERT\*0038

ANNEXES: Documentation technique

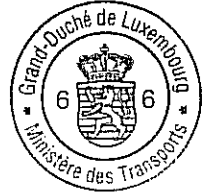

**Statement**

P. 4175

We hereby certify, that the tests described in the technical report from Luxcontrol SA N° LCA 54 327 017 2 concerning the seat belt anchorages of seat type **4135** from manufacturer F.A.S.P. Tappezeria srl, via Golgi, 27, I-25064 Gussago (BS) are in accordance with the requirements of directive 76/115/EEC except for the fact that the seat type was tested on a fix structure representing the vehicle anchorage points. Seats and seat belts were reproducing the loading geometry of the systems with which they can be used.

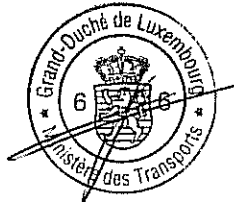

For the Minister of Transport

**Paul SCHMIT**

**Commissaire du Gouvernement**

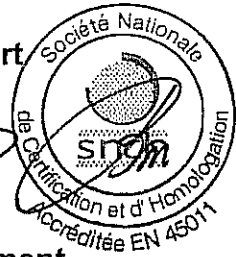

- Attachments:
- Technical report N° LCA 54 327 017 2
  - Manufacturer's information document



**TECHNICAL REPORT**

**No.: LCA 54 327 017 2**

Inspection concerning the

**ANCHORAGES FOR MOTOR-VEHICLE SAFETY BELTS**

performed according to the Directive of the Council of the European Communities

**No. 76 / 115 / EEC**

Seat type:

**4135**

Manufacturer:

**F.A.S.P. Tappezeria srl  
via Golgi, 27  
I – 25064 Gussago (BS)**

Index:

<b>1</b>	<b>General</b>	<b>2</b>
<b>2</b>	<b>Inspection and their results</b>	<b>3</b>
<b>3</b>	<b>Evaluation of test results</b>	<b>5</b>
<b>4</b>	<b>Statement of compliance</b>	<b>7</b>
<b>5</b>	<b>Index</b>	

A reproduction of this report and its annexes, except in full, is prohibited without the written permission of Luxcontrol s.a.

...



\* LCA 54 327 017 2 \* FASP \* 4135 \* 76/115 \* --

## **1**                    **General**

### **1.1**                    **Test Provisions**

The inspection was carried out according to the requirements of the Council Directive of the European Communities 76/115/EEC including all amendments up to 96/38/EC of June 17, 1996.

### **1.2**                    **Information concerning the seat type and the requested attestation**

#### **1.2.1**                    **( ) Numbering according to 76/115/EEC; Section I.**

(0.1.)                    Make (trade name of the manufacturer):

**FASP**

(0.2.)                    Type and general commercial description(s):

Vehicle type:    **Ford Transit**  
Seat type:        **4135**  
Versions:         **--**

(0.3.)                    Means of identification of type, if marked on the vehicle / component / separate technical unit:

**not applicable**

(0.3.1.)                    Location of that marking:

**not applicable**

(0.4.)                    Category of vehicle:

**Seats to be mounted on M<sub>1</sub>, M<sub>2</sub> or M<sub>3</sub> vehicles**

(0.5.)                    Name and address of manufacturer:

**F.A.S.P. Tappezeria srl**  
**via Golgi, 27**  
**I – 25064 Gussago (BS)**

**CERT\*0038**



\* LCA 54 327 017 2 \* FASP \* 4135 \* 76/115 \* --

(0.7.) In the case of components and separate technical units, location and method of affixing of the EC approval mark:

**not applicable**

(0.8.) Address(es) of assembly plants:

**F.A.S.P. Tappezzeria srl  
via Golgi, 27  
I – 25064 Gussago (BS)**

1.2.2 ( ) Numbering according to the 70/115/EEC; Section II.

(1.) Additional information:

(1.1.) Category of vehicle:

**Seats to be mounted on M<sub>1</sub>, M<sub>2</sub> or M<sub>3</sub> vehicles**

(1.2.) Location of anchorages and safety belts provided:

ROW	SEAT	Anchorage position	Anchorage location	
			Vehicle structure	Seat structure
Front	Right-or left-hand seat	lower outboard anchorage	Ar	--
		lower inboard anchorage	--	Ar
		upper anchorage	Ar	--

(5.) Remarks:

**none**

## **2 Inspection and their results**

### **2.1 Version of the tested seat**

Following version has been used for testing (if not stated in part 1.2.2. of this report):

**seat belt anchorage points as shown in Annex B**

CERT\*0038

Société Nationale de Certification et d'Homologation

L-5201 SANDWEILER (Luxembourg)

Organisme accrédité OLAS EN 45011

Accréditation N° 5/001 (Portée communiquée sur demande)



## 2.2 Inspection items

Location of test: Main Report	see item (0.5.)
Date of receipt of test item: Main Report	22.07.2002
Date of test: Main Report	22.07.2002
Inspector: Main Report	A. Tomasini

### 2.2.1 Test configuration:

The seats were tested on a fixed test structure representing the vehicle anchorage points. Seats and seat belts were reproducing the loading geometry of the systems with which they can be used.

### 2.2.2 Dimensional check:

not applicable

### 2.2.3 Strength tests:

The loads were applied using a device comprising a series of hydraulic rams, to apply the safety belt anchorage loads.

## 2.3 Test results:

### 2.3.1 H-point location:

not tested

### 2.3.2 Quantity and design of safety belt anchorages:

In accordance with the Directive.

### 2.3.3 Location of effective belt anchorages:

see drawings in Annex B

CERT\*0038



\* LCA 54 327 017 2 \* FASP \* 4135 \* 76/115 \* --

#### 2.3.4 Strength tests:

Loads were applied as rapidly as possible, in accordance with the Directive.

All anchorages sustained the test loads simultaneously for the required time, without rupture. After test, the minimum spacing for the effective lower belt anchorages and the location requirements for the effective upper belt anchorages were still in compliance with the Directive.

Test No.	Date	Seat configuration	Safety Belt Arrangement	Remarks
1	22.07.2002	front seat	Ar	Supplemental force of 20 times the weight of heaviest version of seat, applied horizontally and longitudinally through center of gravity of seat.

#### 2.4 Remarks

##### 2.4.1 General:

The inspection results are only applicable to items which have been tested.

#### 2.5 Test facilities

Calibration of measuring and test equipment used to carry out the inspections is in accordance with the EEC-Directive and/or ECE-Regulation stated in 1.1. of this report and with ISO 17025.

Inspectors stated under 2.3. of this report were in charge of performing and/or evaluating the tests.

### 3 Evaluation of test results

#### 3.1 Variants and equipment covered

The test results carried out cover the following variants as far as these are relevant for the safety belt anchorages:

- not applicable

CERT\*0038



\* LCA 54 327 017 2 \* FASP \* 4135 \* 76/115 \* --

**3.2**

**Remarks**

3.2.1

Main report:

not applicable

**CERT\*0038**

Société Nationale de Certification et d'Homologation

L-5201 SANDWEILER (Luxembourg)

Organisme accrédité OLAS EN 45011

Accréditation N° 5/001 (Portée communiquée sur demande)



\* LCA 54 327 017 2 \* FASP \* 4135 \* 76/115 \* --

#### 4 Statement of compliance

The inspection items and measurements carried out have shown the compliance of the vehicle type described in this report and the attached Annex with the requirements of the Council Directive of the European Communities 76/115/EEC including all amendments up to 96/38/EC of June 17, 1996.

Esch/Alzette, 23.4.2003

Luxcontrol s.a.  
Service Homologation-Automobile

Paul Wax  
Ingénieur inspecteur

David Durazzi  
Ingénieur inspecteur

Annex

CERT\*0038





\* LCA 54 327 017 2 \* FASP \* 4135 \* 76/115 \* --

---

Index to the information package, including a summary in chronological order,  
concerning extensions and/or amendments

---

## **Main Report**

Technical Report No.: LCA 54 327 017 2

Pages 1 to 7

### Composition of the Annex:

A: Index

Page 1

B: Test photos

Pages 1 to 4

C: Information folder

Pages 1 to 6

## **Index to the information folder**

- manufacturer's information document (pages 1 to 6)

---

CERT\*0038

Société Nationale de Certification et d'Homologation

L-5201 SANDWEILER (Luxembourg)

Organisme accrédité OLAS EN 45011

Accréditation N° 5/001 (Portée communiquée sur demande)



Photographs before test





Photographs before test

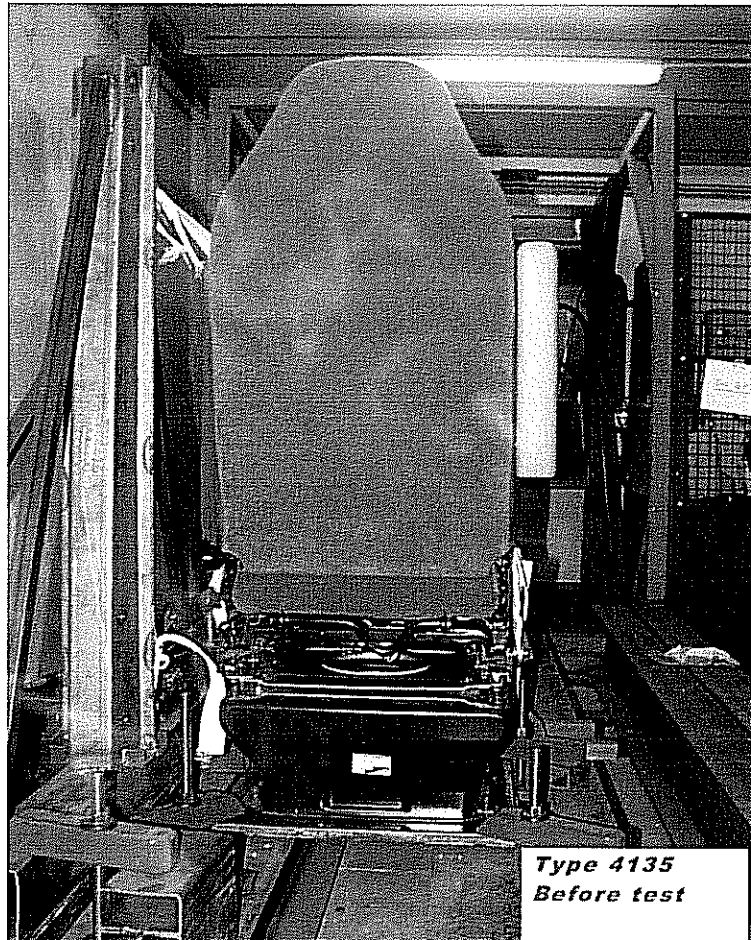



Photographs after test

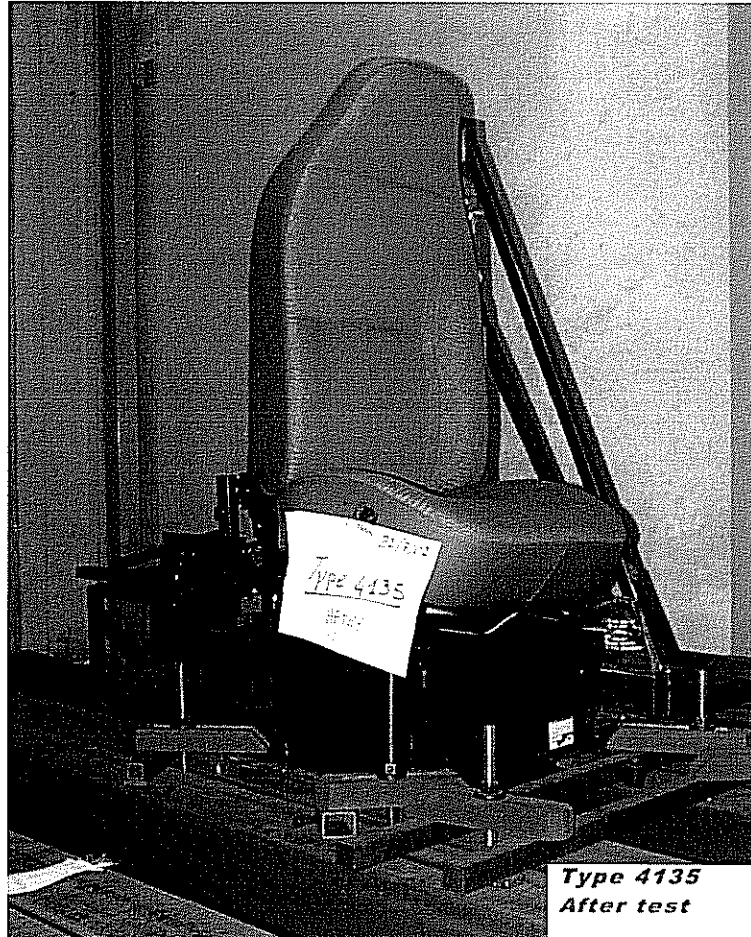

CERT\*0038

Société Nationale de Certification et d'Homologation  
L-5201 SANDWEILER (Luxembourg)  
Organisme accrédité OLAS EN 45011  
Accréditation N° 5/001 (Portée communiquée sur demande)



Photographs after test

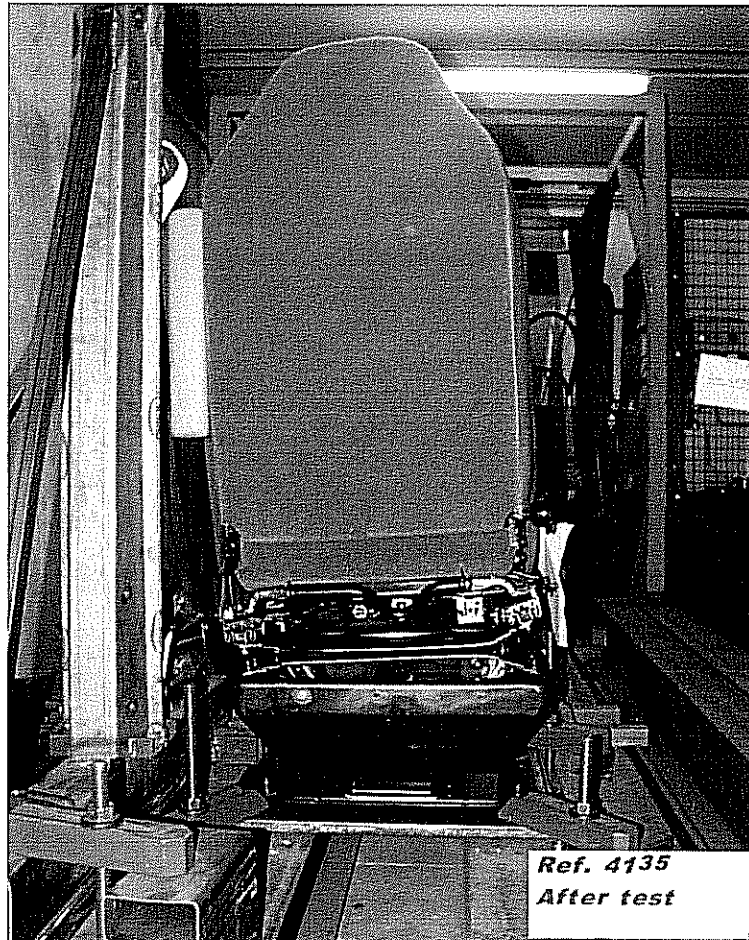

CERT\*0038

Société Nationale de Certification et d'Homologation  
L-5201 SANDWEILER (Luxembourg)  
Organisme accrédité OLAS EN 45011  
Accréditation N° 5/001 (Portée communiquée sur demande)

**Specification sheet for single seat type 4135**

**Seat specification:**

**Original Ford seat (driver and passenger side) with original Ford support**

**Seat weight: Kgs 30 max**

**Dimension: Max width mm 500 - max height mm 1290**

**Use: M1/M2/M3 Vehicles**

**Rotating platform specification:**

**Material: FE P04 high deformation sheet iron**

**Weight: Kgs. 10,0**

**Dimension: mm 450 x mm 460 x H mm 31**

**Rotation: by double ball-bearing device**

**Use: M1/M2/M3 vehicles**

**Methode of employment on vehicle:**

- **Original seat support**
- **Fasp rotating platform**
- **Original Ford seat**

**FAST/TEPPEZZERIA SRL**  
**25064/0023AGG (BS)**

**Ford4135**

**CERT\*0038**

**Ref.-no**

**327 017 2**

**PAGE**

**001**



NB. IL FIGURINO RAPPRESENTA IL DESTRO (PASSEGGERO)

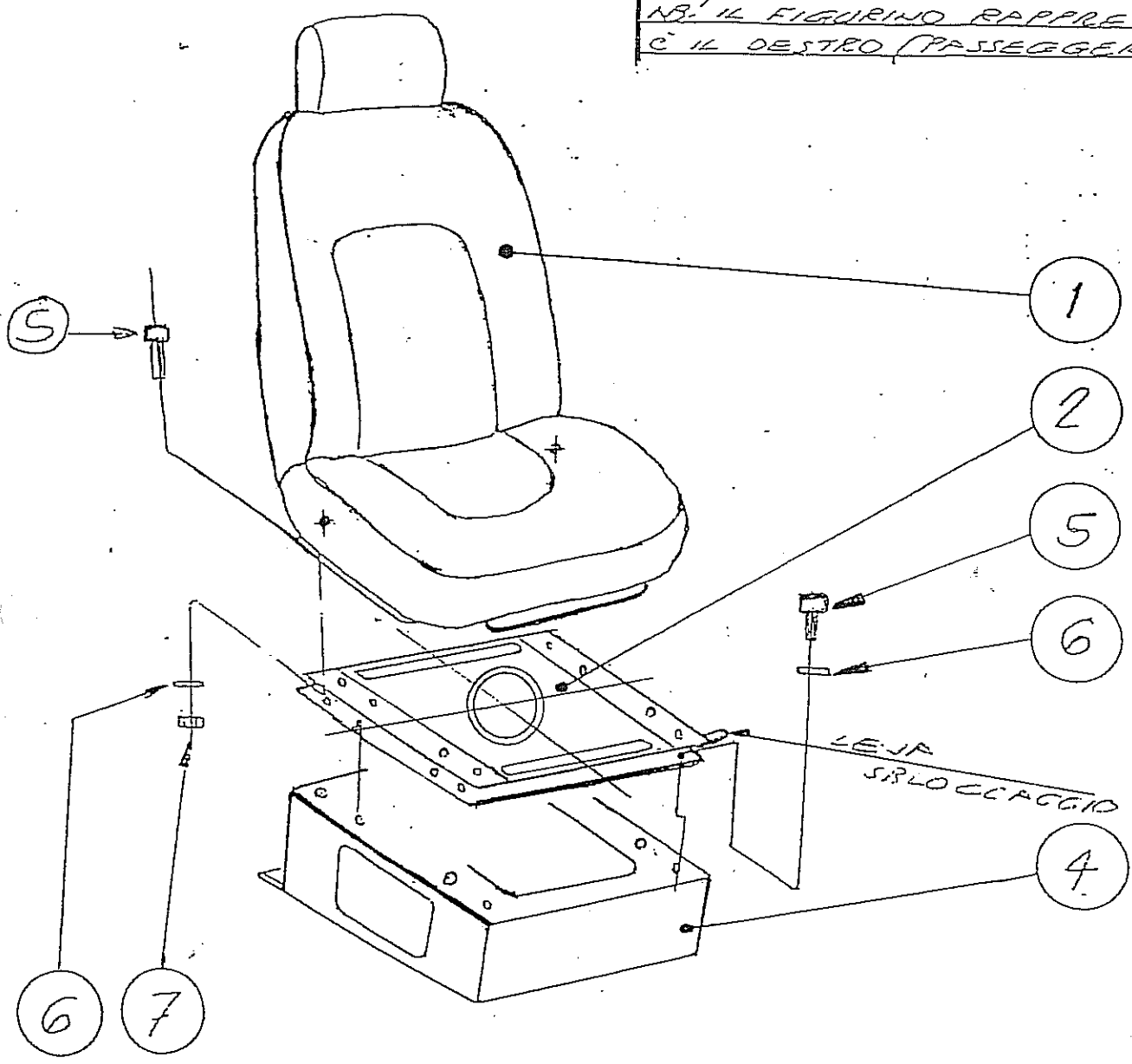

Ref.-no PAGE  
327 017 2 003

7	dado basso M8 uni5589	5	comm.	C.8.8 zincato	
6	Rondella piana M8 uni6592	10	comm.	C.8.8 zincato	
5	Vite TE M8x20 uni5931	10	comm.	C.8.8 zincato	
4	Supporto originale Ford	1			kg 5
3					
2	Piastra girevole	1		4115 Fe P04	
1	Sedile originale Ford Transit	1			Kg 10
POS.	DENOMINAZIONE	Q.TA'	DISEGNO	MATERIALI/NOTE	PESO

N.	MODIFICHE	ESEGUITA	DATA
1			
2			
3			

DESCRIZIONE  
**FORD TRANSIT**

**Assieme montaggio**

CERTIFICAZIONE 0038  
Société Nationale de Certification et d'Homologation  
L-5201 SAN DIEWEILER (Luxembourg)  
Accréditation N° 5/01 (MRT) - Liste communiquée sur demande

DATA \_\_\_\_\_ SCALA \_\_\_\_\_ DISEGN. **MASSI**

**F.A.S.P.** TAPPEZZERIA srl  
INTERNI AUTOBUS - CAMPER - NAUTICA  
VIA GOLGI, 27 - 25064 GUSSAGO (BRESCIA) ITALY  
TEL. 030 321776 - 030 321885 - FAX 030 322281  
www.fasp.it - e-mail: info@fasp.it

MATERIALE	TRATT.
FOGLIO	
CIS. N. 4135 dx/sx	





TOLLERANZE GENERALI  
 UNI5307 GP PRECISO

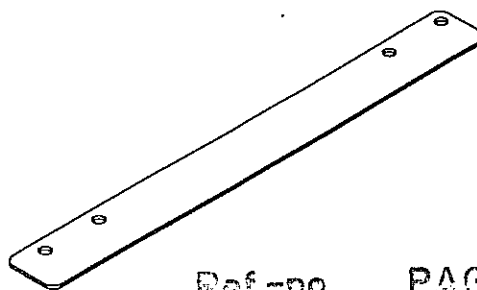
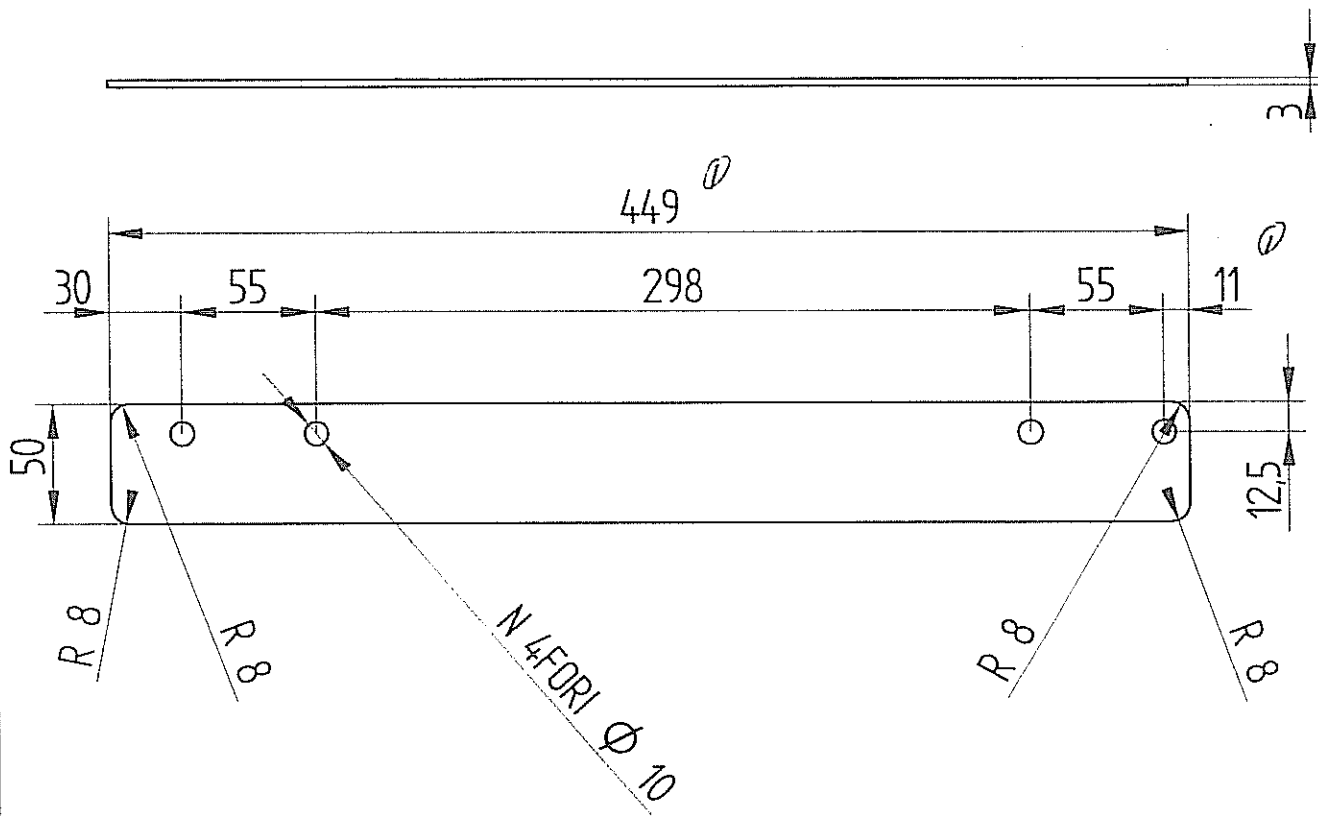

Ref.-no PAGE  
 327 017 2 005

N.	MODIFICHE	ESEGUITA	DATA
1	AGGIUNTA	<i>[Signature]</i>	3-7-02
2			
3			

DESCRIZIONE	LAMIERA PROSEGUITO PIASTRA	CLIENTE	
	LAMIERA sp. 3		
Q.TA'	MATERIALE	TRATT.	
	Fe 360C		
DATA	SCALA	DISEGN.	FOGLIO
04/07/2002		MASSI	LAM4115_2

**TRAPPEZZERI S.R.L.**  
 INTERNI AUTOBUS - CAMPER - NAUTICA  
 Via Golgi 27 - 25064 GUSSAGO (BS)

MASSI CERT 0038  
 Société Royale de Certification et d'Homologation  
 L-5201 SANDWELLER (Luxembourg)  
 Organisme accrédité OLAS EN 45011  
 Accréditation N° 5/001 (Portée communiquée sur demande)

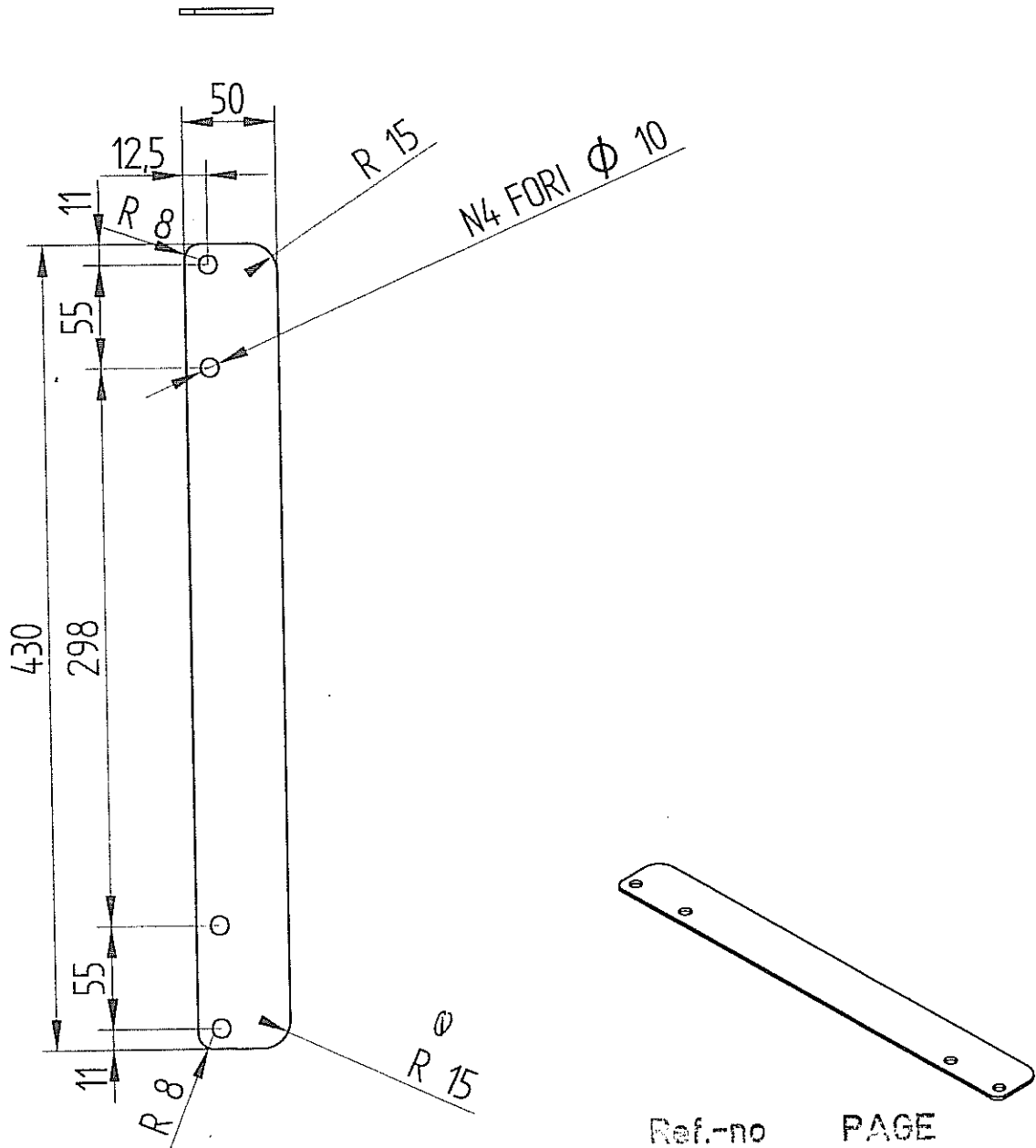

TOLLERANZE GENERALI  
UNI5307 GP PRECISO

Ref.-no PAGE  
327 017 2 006 1

POS.	DENOMINAZIONE	Q.TA'	DIS. N.	MATERIALE E NOTE	PESO UNIT.
N.	MODIFICHE	ESEGUITA	DATA	 <p><b>FASE</b> FABBRICAZIONE S.P.A. INTERNI AUTOBUS - CAMPER - NAUTICA Via Golgi 27 - 25054 GUSSAGO (BS)</p>	
1	ACQ. ORIZ.	<i>[Signature]</i>	7-3-02.		
2					
3					
DESCRIZIONE				Q.TA'	MATERIALE
LAMIERA PROSEGUITO PIASTRA					Fe360C
LAMIERA sp3					TRATT.
CLIENTE					
DATA	SCALA	DISEGN.	Q.TA'	DIS. N.	FOGLIO
04/07/2002		Nicola		LAM4115_1	